

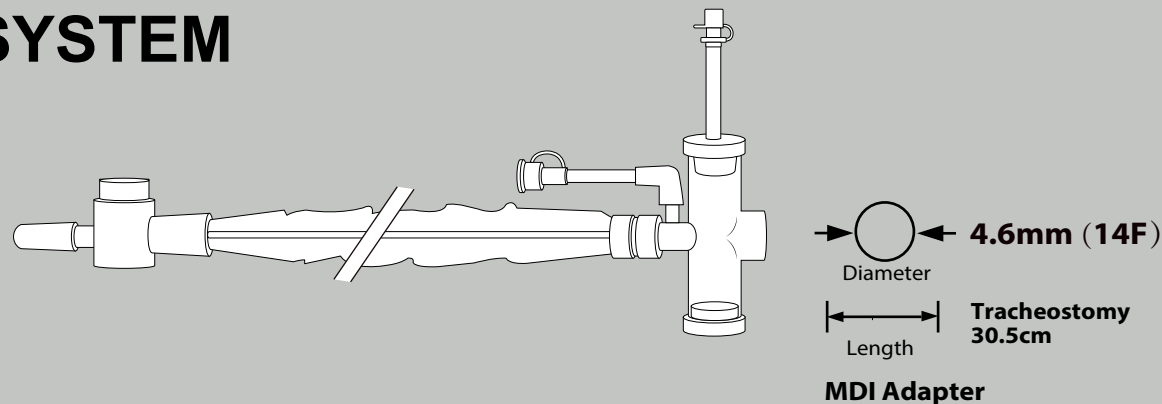

Tracheostomy

CLOSED SUCTION SYSTEM

T-Piece Adult







Contents:

- 1 Closed Suction Catheter
- 1 MDI Adapter
- 1 22mm Flex Adapter
- 1 15mm x 22mm Adapter
- 1 15mm Straight Swivel Adapter
- 1 Day Sticker

Trudell Healthcare Solutions
 758 Baransway Drive
 London, Ontario
 Canada, N5V 5J7
 Made in China

REF T19TPT114  YYYY-MM
 LOT KSYYMMXXX  YYYY-MM-DD

 DO NOT RE-USE	STERILE R	 DO NOT RESTERILIZE	NOT MADE WITH NATURAL RUBBER LATEX	Rx Only	NOT MADE WITH DEHP	 DO NOT USE IF PACKAGE IS DAMAGED	 CONSULT INSTRUCTIONS FOR USE
---	------------------	--	------------------------------------	----------------	--------------------	--	--



CLOSED SUCTION SYSTEM

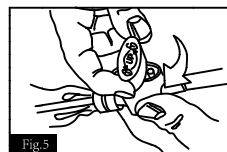
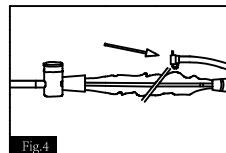
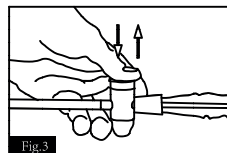
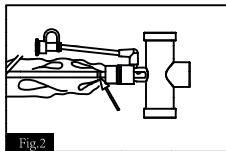
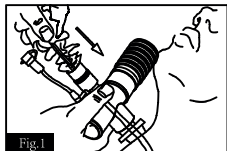

Directions For Use:

These instructions apply to the TruTest® Closed Suction System:

Warning:

1. Remove cap on T-Piece before starting continuous flow therapy. Failure to do so may result in serious injury or death.
2. This medical device is not intended for re-use. Do not re-use, reprocess or resterilize.

Cautions:

1. If packing has been compromised do not use product.
2. If a heat and moisture exchanger (HME) is used, ensure that excess fluid does not enter the HME (not included).
3. This is a single patient use only device.
4. The TruTest® Closed Suction System is intended to be used for a 24-hour period before changing. Change more frequently if catheter becomes heavily soiled during use.
5. Select the appropriate size TruTest® Closed Suction System. Most experts suggest that the catheter selected should occupy no more than one half of the internal diameter of the artificial airway.
6. Do not leave catheter within the airway. Always pull catheter back until the black stripe is visible within the sleeve. Any catheter left extended into the airway will cause increased airway resistance.
7. When choosing an appropriate regulated vacuum level consider that most experts suggest -80 to -120 mm/Hg (-10.7 to -15.9 kPa).

8. Use appropriate suction technique. Most experts suggest the suction procedure should last no longer than 10 to 15 seconds with actual duration of negative pressure no longer than 5 to 8 seconds per episode.
9. Always place the thumb valve in the locked position when not in use to prevent inadvertent activation.
10. This medical device is not made with di (2-ethyl hexyl) phthalate (DEHP).
11. The internal volume of patient end adapter is 14 ml. The internal volume of flex adapter is 23 ml.
12. Use tracheostomy 30.5 cm catheters for patients with tracheostomy artificial airways only. If 30.5 cm catheter is used on endotracheal artificial airway, ineffective suction may result.
13. Always use caution and good clinical judgment no matter what ventilator mode is in use. If the clinician notes any signs of suction intolerance such as oxygen desaturation, negative ventilator catheter pressures, patient stress or excessive discomfort, adjustments to the ventilator settings may need to be made. These adjustments (please refer to the ventilator's instructions for use) may include manipulation of the inspiratory trigger sensitivity, inspiratory volume or flow rate, and selection of a different ventilator mode; or may require the use of an alternate suction technique. Failure to follow the above precautions may increase the risk of positive and negative barotrauma.

Setup:

1. Select an appropriate size TruTest® Closed Suction System.
2. Apply suction tubing to thumb control valve.
3. Simultaneously depress and hold thumb valve and adjust vacuum regulator to desired level.
4. After releasing thumb control valve, attach TruTest® Closed Suction System between patient and the breathing circuit.

Suggested Suction Procedure:

1. Always stabilize TruTest® Closed Suction System and tracheostomy tube adapter with one hand while pushing the catheter into tracheostomy tube with the thumb and forefinger of the opposite hand (Fig. 1).
2. Advance catheter to desired depth.
3. Press and hold thumb control valve. Gently withdraw catheter and stop withdrawal when black marking ring is visible inside sleeve (Fig. 2).
4. Release thumb control valve.
5. Repeat steps 1 - 4 above as needed.

Patient Lavage Instructions:

1. Catheter should be advanced 3 - 4 cm into the tracheostomy tube.
2. Instill desired amount of fluid into the lavage port.
3. Advance catheter to desired depth and follow the above suggested suction procedure.

Catheter Irrigation Instructions:

1. The black marking ring must be visible in the sleeve (Fig. 2); then open cap on irrigation port.
2. Slowly introduce fluid into the port, while depressing the thumb control valve (Fig. 3).

3. Irrigate until catheter is clear (Fig. 4).
4. Close cap on port.
5. Lock the control valve by lifting and turning it 180 degrees (Fig. 5).
6. Position catheter and suction tubing beside breathing circuit.

Metered Dose Inhaler (MDI): (Not Included)

1. Remove cap from MDI port and attach canister. Caution should be used to avoid discharge of canister when connecting.
2. Holding MDI canister in vertical position, depress during, or just prior to an inspiration cycle. Repeat as needed per physician or protocol.
3. Place cap on port after removing canister.

End Tidal CO₂ Monitor Connection:

1. Predetermine appropriate tubing for attachment to luer fitting.
2. Remove luer cap and attach tubing from CO₂ analyzer to begin sampling.

Day Sticker Usage:

1. The TruTest® Closed Suction System is intended for a 24-hour period. Apply the appropriate day sticker to the thumb control valve.
Example: If the system is opened on Monday, place the Tuesday sticker on thumb control valve.